



D₃₀₀ · D₅₀₀
5-Axis Vertical Machining
Center

D series



www.makino.co.jp



Atsugi and Fuji Katsuyama works are certified for ISO14001 and ISO9001.

*The specifications, figures, and overviews of products, peripheral devices and accessories in this catalogue may be changed without prior notice to incorporate improvements resulting from ongoing R&D programs.
*The all products in this catalogue include the optional specifications and equipment.
*The products, including technical data and software, may be subject to the Foreign Exchange and Foreign Trade Control Law in Japan.
Prior to any re-sale, re-transfer or re-export, please contact Makino to obtain any required authorization and approval.



The 5-Axis Vertical Machining Center brings
**Smooth launch on job-shop,
 and surefire success.**

5-Axis Vertical Machining Center
Dseries



— Photo: D500 —

- Minimal-interference table and spindle-head — PAGE 3
- Controller Professional 6 — 5
- Spindles — 6
- Cutting performance / Machining example — 7
- Chip evacuation — 10
- Structure for smooth operation — 12
- Automation — 14
- Specification list — 15

Leading an operator and a machine
Professional 6 [Controller]

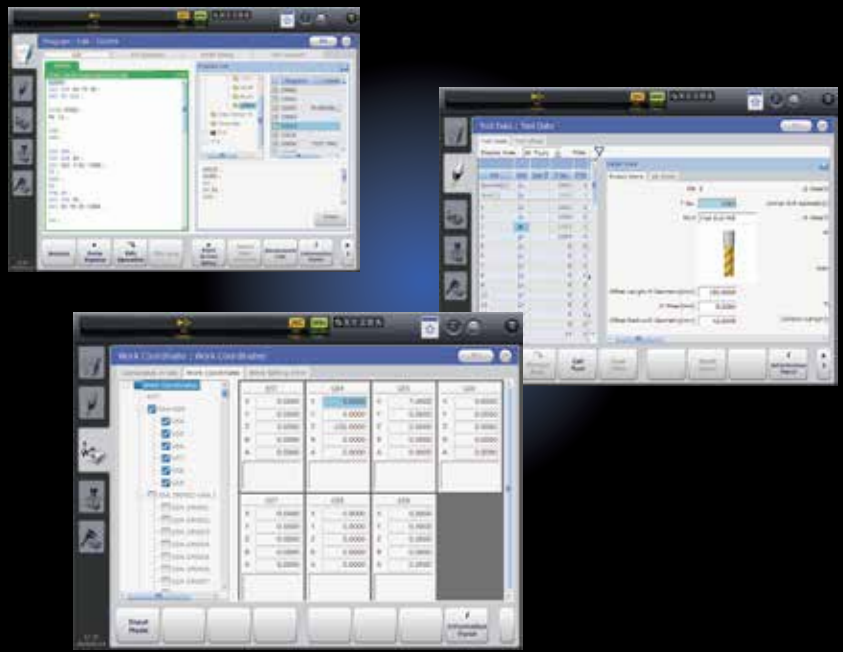

Minimal-interference table and spindle-head



Photo: D500/2000 min⁻¹ spindle (optional specification)

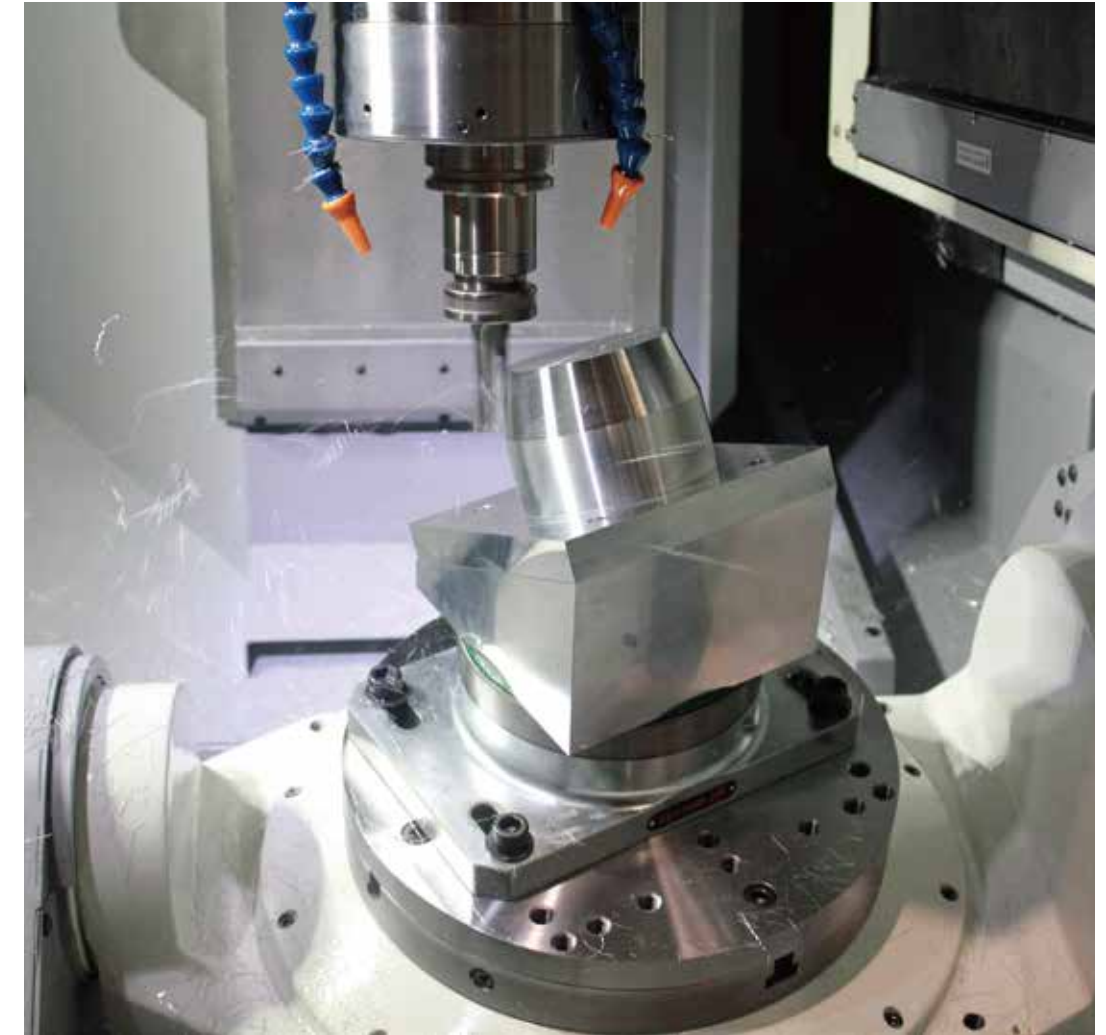

Photo: D300

D300

Travels

- X × Y × Z axis : 300 × 500 × 350 mm
- A axis (tilting axis) : 240 deg. (±120 deg.)
- C axis (rotating axis) : 360 deg. (continuous rotation)

Maximum payload: 120 kg

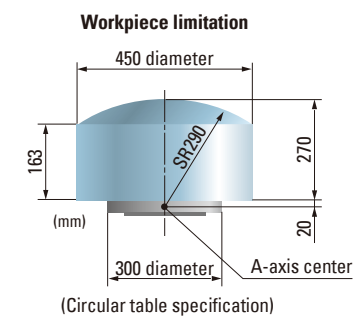

D500

Travels

- X × Y × Z axis : 550 × 1000 × 500 mm
- A axis (tilting axis) : 150 deg. (-120 deg. to +30 deg.)
- C axis (rotating axis) : 360 deg. (continuous rotation)

Maximum payload: 350 kg

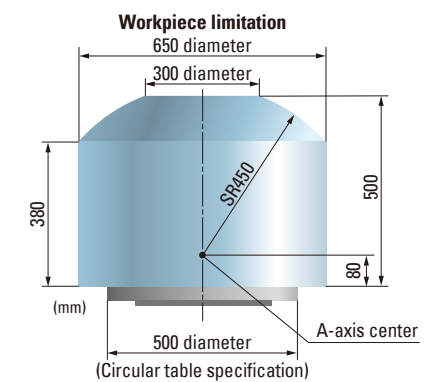

Collision safeguard

Real time interference check

Before machining, Collision Safeguard checks errors of tooling, and setting errors of tool length to minimize emergency stoppages. Then, during machining, it monitors machine behavior and detects interference in advance to stop the machine before collision.

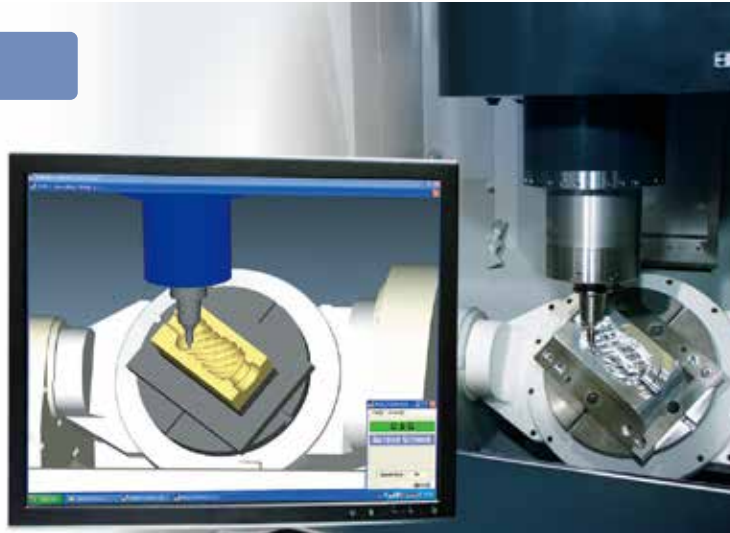

High-speed smooth TCP

Smooth control motion of simultaneous 5-axis machining

Tool center point is automatically controlled so that it moves along the programmed toolpath at the commanded speed even if the orientation of the tool changes.

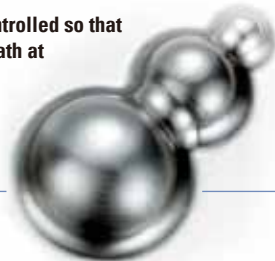

Machining example

Improve machined surface quality and shortens machining time drastically

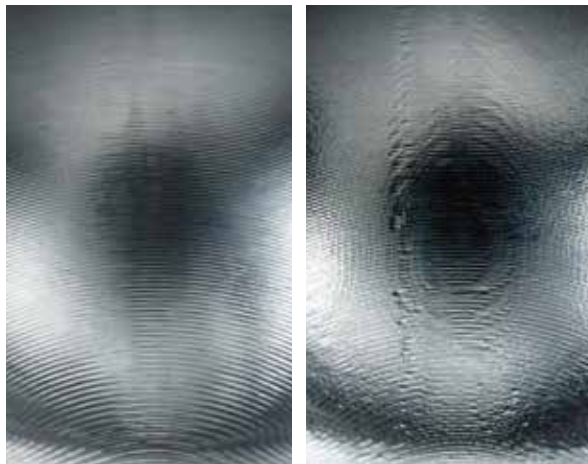

ON

OFF

i Setup (optional equipment)

- It is quick at intuitive operation and easy measurement environment is realized.
- Easy operation by dialog screen that is cord-free.



Photo: D300/ 20000 min⁻¹ spindle (optional specification)

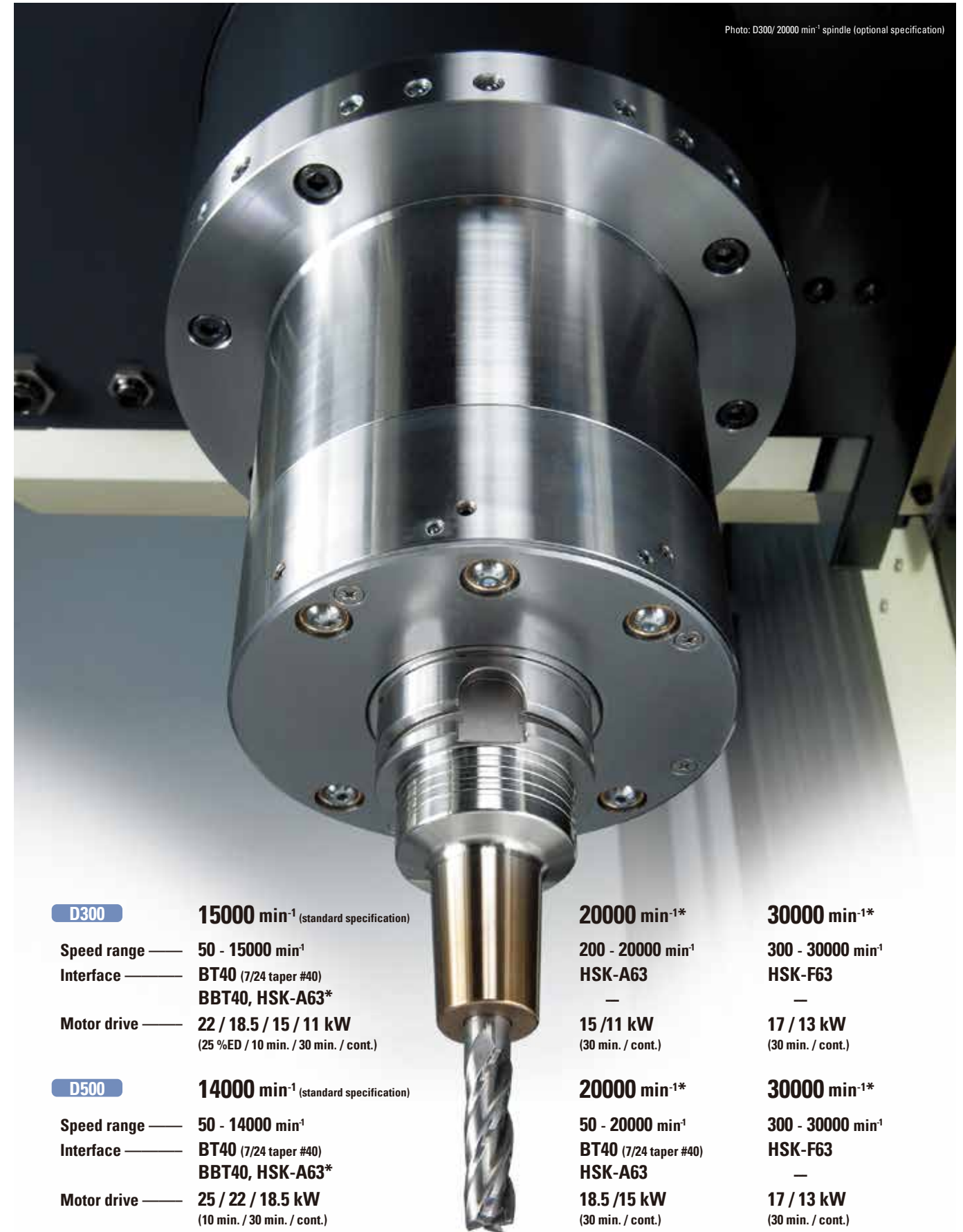

	D300	15000 min⁻¹ (standard specification)	20000 min⁻¹*	30000 min⁻¹*
Speed range	50 - 15000 min ⁻¹		200 - 20000 min ⁻¹	300 - 30000 min ⁻¹
Interface	BT40 (7/24 taper #40) BBT40, HSK-A63*		HSK-A63	HSK-F63
Motor drive	22 / 18.5 / 15 / 11 kW (25 %ED / 10 min. / 30 min. / cont.)		15 / 11 kW (30 min. / cont.)	17 / 13 kW (30 min. / cont.)
	D500	14000 min⁻¹ (standard specification)	20000 min⁻¹*	30000 min⁻¹*
Speed range	50 - 14000 min ⁻¹		50 - 20000 min ⁻¹	300 - 30000 min ⁻¹
Interface	BT40 (7/24 taper #40) BBT40, HSK-A63*		BT40 (7/24 taper #40) HSK-A63	HSK-F63
Motor drive	25 / 22 / 18.5 kW (10 min. / 30 min. / cont.)		18.5 / 15 kW (30 min. / cont.)	17 / 13 kW (30 min. / cont.)

(*optional specification)

Cutting performance



D300	Face mill	End mill	Drill	Tap
Material	: Aluminum (A5052) : Steel (S50C)	: Aluminum (A5052) : Steel (S50C)	: Aluminum (A5052) : Steel (S50C)	: Aluminum (A5052) : Steel (S50C)
Tool diameter	: 63 mm : 50 mm	: 20 mm : 16 mm	: 35 mm : 35 mm	: M24-3.0 : M20-2.5
Radial depth of cutting	: 50 mm : 35 mm	: 14 mm : 14 mm	—	—
Axial depth of cutting	: 5 mm : 3 mm	: 15 mm : 2.5 mm	: 35 mm : 35 mm	: 24 mm : 20 mm
Metal removal rate	: 1364 cm ³ /min : 209 cm ³ /min	: 936 cm ³ /min : 56 cm ³ /min	: 245 cm ³ /min : 221 cm ³ /min	—
Spindle speed	—	—	—	: 300 min ⁻¹ : 250 min ⁻¹

D500	Face mill	End mill	Drill	Tap
Material	: Aluminum (A5052) : Steel (S50C)	: Aluminum (A5052) : Steel (S50C)	: Aluminum (A5052) : Steel (S50C)	: Aluminum (A5052) : Steel (S50C)
Tool diameter	: 80 mm : 80 mm	: 20 mm : 32 mm	: 48 mm : 48 mm	: M30-3.5 : M30-3.5
Radial depth of cutting	: 60 mm : 60 mm	: 15 mm : 20 mm	—	—
Axial depth of cutting	: 4 mm : 4 mm	: 14 mm : 8 mm	: 20 mm : 20 mm	: 20 mm : 20 mm
Metal removal rate	: 2400 cm ³ /min : 480 cm ³ /min	: 2016 cm ³ /min : 216 cm ³ /min	: 445 cm ³ /min : 206 cm ³ /min	—
Spindle speed	—	—	—	: 106 min ⁻¹ : 106 min ⁻¹

D300: 20000 min⁻¹ spindle
D500: 14000 min⁻¹ spindle

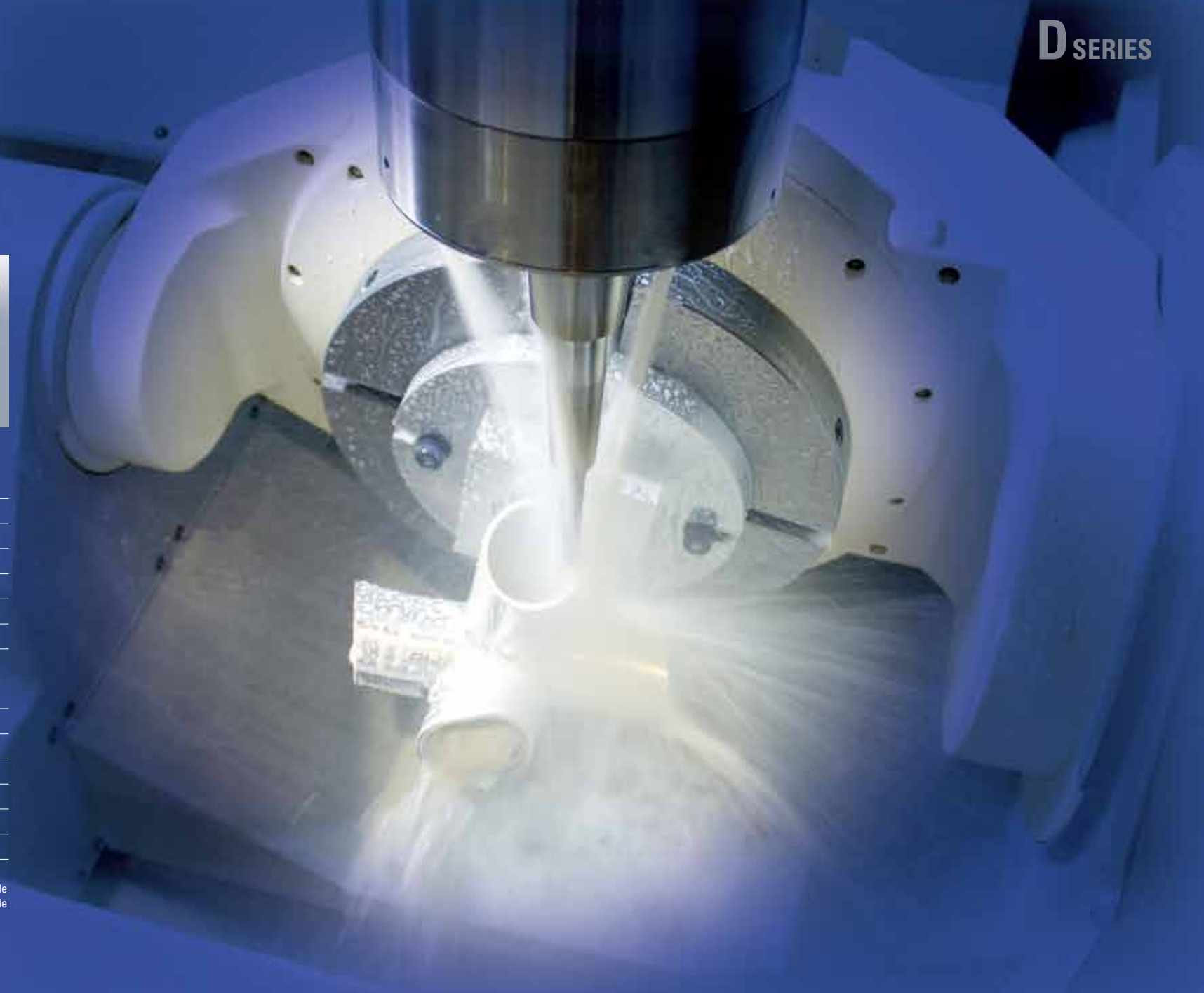

Machining example

D300

Die cast mold part

Material : Tool steel (SKD61, 48HRC)
Size : 104 × 74 × 100 mm
Number of tools : 5
Machining time : 1 hr. 26 min.



Triple splitter impeller

Material : Titanium (Ti-6Al-4V)
Size : Diameter 196 × 90 mm
Number of tools : 6
Machining time : 4 hr. 22 min.



Roller

Material : Carbon steel (SCM420H, 62HRC)
Size : Diameter 120 × 35 mm
Tool used : cBN Electroplated grinding wheel, diamond grinding wheel
Machining time : 1 hr. 31 min. 50 sec.

Roundness (circumferential/ height direction)
2.0 μm / 2.0 μm

Surface finish (circumferential/ height direction)
Rz0.5 μm / Rz1.0 μm

*Requires the special specification for grinding machining.



Inserts of plastic mold

Material : Mold steel (PX5, 33HRC)
Size : 75 × 60 × 65 mm
Number of tools : 3
Machining time : 1 hr. 24 min.



D500

Plastic mold (core)

Material : Mold steel (PX5, 33HRC)
Size : 440 × 260 × 300 mm
Number of tools : 30
Machining time : 71 hr. 24 min.



Knuckle arm

Material : Aluminum (A5052)
Size : Diameter 300 × 100 mm
Number of tools : 14
Machining time : 41 hr. 51 min.



Crankcase cover

Material : Aluminum (A5052)
Size : 285 × 75 × 170 mm
Number of tools : 3
Machining time : 30 hr.



Slide core

Material : Mold steel (PX5, 33HRC)
Size : 300 × 200 × 165 mm
Number of tools : 24
Machining time : 12 hr. 47 min.



Chip evacuation

By nozzle coolant supply device and shower coolant^{*1}, chips are flushed into the troughs along the table. Then, they are reliably evacuated from machine by the base coolant and Lift-up chip conveyor^{*3}.

Nozzle coolant / shower coolant^{*1}



(*1: optional equipment) Photo: D300

Base coolant / conveyor in splash guard^{*2}

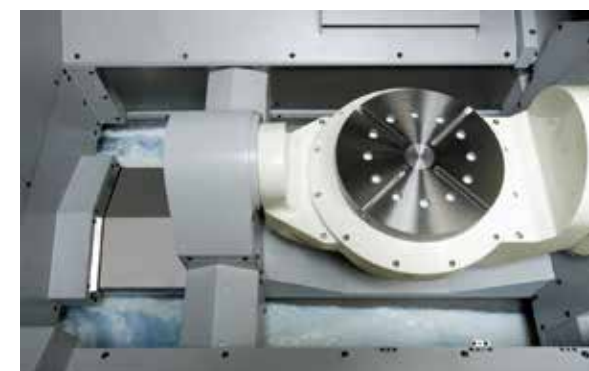

(*2: optional specification) Photo: D300

Lift-up chip conveyor^{*3}

D300 Lift-up chip conveyor with coolant filtration (scraper type)
(optional equipment)



D500 Lift-up chip conveyor with coolant filtration (scraper type)

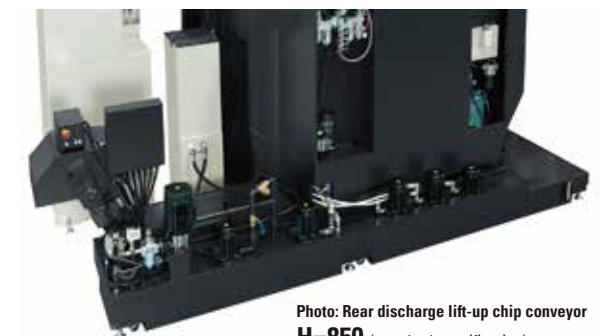

Photo: Rear discharge lift-up chip conveyor H=850 (standard specification)



Photo: Front discharge lift-up chip conveyor H=1250 (optional specification)

(*3: Refer to Page 16 specification list.)



Photo : D500
Pallet table specification
(optional specification)

Structure for smooth operation



Photo : D500/Pallet table specification (optional specification)

Operator-friendly design

Tool tip and workpiece can be checked in natural posture.
Furthermore, workpiece loading is easy, thanks to the full overhead clearance for crane.



Photo: D300



Photo: D500 / Front discharge lift-up chip conveyor H1250 spec.* (*optional specification)



Photo: D300 / Thermal Guard (optional equipment), lift-up chip conveyor spec. (optional equipment)



Photo: D300



Center of Rotation Axis measurement

Before special high precision machining, center of rotation axes can be measured easily.

Maintenance

Units that require daily checking are concentrated on the side of the machine

Automation



Photo: D500/Automatic tool changer



Photo: D300/Automatic pallet changer (optional specification)

Automatic tool changer

		D300	D500
No. of tool storage capacity	(standard)	40	40
	(optional)	60, 124	60, 80, 113, 155, 197, 239, 281, 323
Maximum weight (kg)		8	8
Change time (sec)		0.8 (tool-to-tool)	4.2 (tool-to-tool)

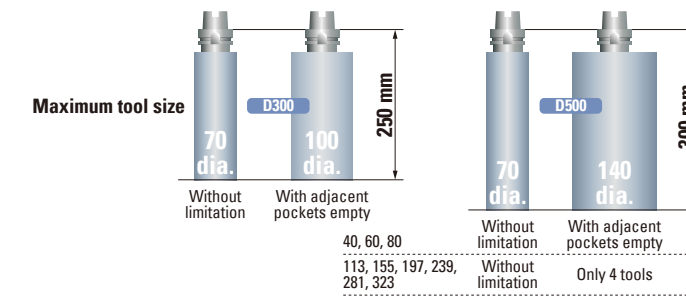

Photo: D300

Non-contact tool length measuring device



(optional specification)

Automatic workpiece measuring device



(optional equipment)

Automatic pallet changer

(optional specification)

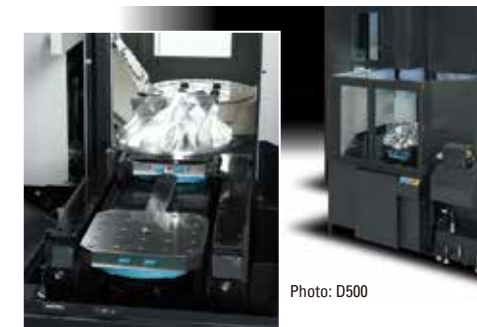

Photo: D500



Photo: D300



Photo: D500/ Pallet magazine specification

Automatic work changer (loading example)

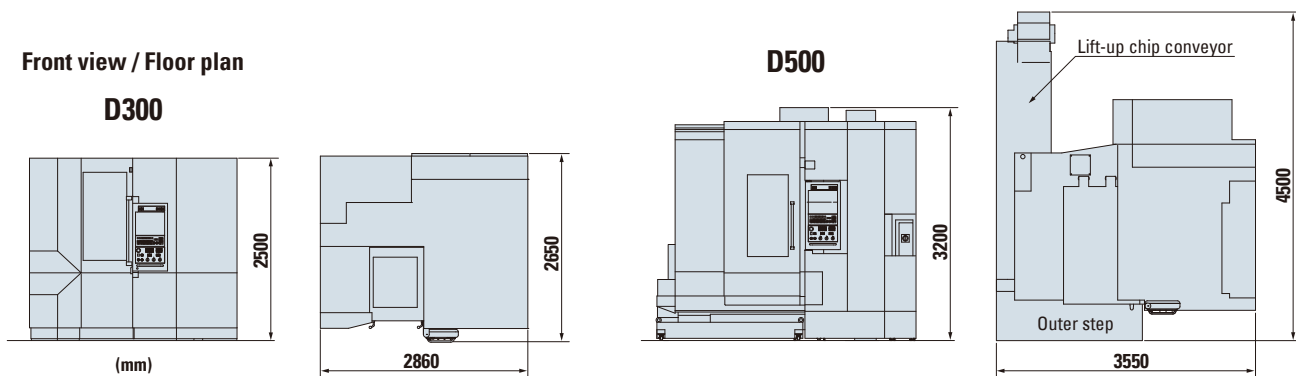

Photo: D300

	D300	D500
Number of pallets	2	2
Exchange method	Two pallets simultaneous change by turning arm	
Exchangeable workpiece weight (kg)	100	500

- Robot shutter*
 - Pallet magazine*
 - Loader interface*
- (*optional specification)

Specifications (standard specifications)		D300	D500	
Travels	X × Y × Z axis	300 × 500 × 350 mm	550 × 1000 × 500 mm	
	A axis	240 deg. (±120 deg.)	150 deg. (-120 deg. to +30 deg.)	
	C axis	360 deg. (continuous rotation)	360 deg. (continuous rotation)	
Table	Size (diameter)	300 mm	500 mm	
	Maximum workpiece size (diameter × height)	450 × 270 mm (with limitation)	650 × 500 mm (with limitation)	
	Maximum payload	120 kg	350 kg	
	Surface configuration	T-slot (12H8 × 4 slots)	T-slot (18H8 × 8 slots)	
Spindle	Speed range	50 - 15000 min ⁻¹	50 - 14000 min ⁻¹	
	Motor drive	22 / 18.5 / 15 / 11 kW (25%ED / 10 min. / 30 min. / cont.)	25 / 22 / 18.5 kW (10 min. / 30 min. / cont.)	
	Torque	120 / 99 / 77 / 42 N·m (10%ED / 15%ED / 25%ED / cont.)	201 / 167 / 118 / 96 N·m (15%ED / 25%ED / 15 min. / cont.)	
	Interface	BT40 (7/24 taper #40)	BT40 (7/24 taper #40)	
	Bearing diameter (inner)	70 mm	85 mm	
	Number of speed range	2 step with electric changeover	2 step with electric changeover	
	Cooling / lubrication	Jacket / Oil-air	Jacket / Oil-air	
Feedrates	Rapid traverse	X, Y, Z axis	60000 mm/min	48000 (X axis), 50000 (Y, Z axis) mm/min
		A axis	45000 deg./min	18000 deg./min
		C axis	54000 deg./min	18000 deg./min
	Cutting feed	X, Y, Z axis	1 - 60000 mm/min	1 - 32000 (X axis), 40000 (Y, Z axis) mm/min
		A axis	1 - 45000 deg./min	1 - 18000 deg./min
		C axis	1 - 54000 deg./min	1 - 18000 deg./min
Automatic tool changer	Tool shank	JIS B6339 40T	JIS B6339 40T	
	Retention knob	JIS B6339 40P	JIS B6339 40P	
	Tool storage capacity	40-tool	40-tool	
	Maximum tool diameter (without limitation / with limitation)	70 / 100 mm	70 / 140 mm	
	Maximum tool length	250 mm	300 mm	
Machine size (standard)	Maximum tool weight	8 kg	8 kg	
	Height	2500 mm	3200 mm	
	Width × Depth	2860 × 2650 mm	3550 × 4500 mm	
Floor space	Weight (including NC unit)	7600 kg	15700 kg	
	Width × Depth	3380 × 4805 mm 3560 × 3695 mm	4900 × 4500 mm	



* The space for the movable parts and maintenance in addition to the space for the machine main body are required. For the details, please refer to the specification.

Standard Specifications | ● D300 | ● D500

- | 15000 min⁻¹ spindle
- | 14000 min⁻¹ spindle
- | Spindle temperature controller
- | 300 mm diameter T-slot circular table
- | 500 mm diameter T-slot circular table
- | 40-tool magazine
- | Base coolant
- | Nozzle coolant (D300: Built-in 6 nozzles / D500: 8 nozzles)
- | Through spindle air
- | Lift-up chip conveyor with coolant filtration (scraper type, 820 L) H=850 *Select front or rear type
- | Program storage edit user memory 2GB +1GB
- | Registered program number 1000
- | Operator door interlock (operation mode)
- | Automatic grease supply unit
- | Lighting device (for machining chamber) (with 1 LED lamp)
- | Portable manual pulse generator (with the handle enable button)
- | Rigid tapping
- | Tilted working plane indexing command
- | High Speed Smooth TCP
- | 3-dimensional cutter compensation
- | Standard tool length function
- | GI control
- | Super GI.5 control
- | Helical interpolation
- | ECO mode functions
- | Collision Safeguard
- | Automatic power-off function
- | Automatic fire extinguisher interface

Optional Specifications | ■ D300 | ■ D500
Optional Equipment | ★ D300 | ★ D500

- | 20000min⁻¹ spindle (HSK-A63 only)
- | 30000min⁻¹ spindle (HSK-F63 only)
- | Tool magazine (60, 124 tools)
- | Tool magazine (60, 80, 113, 155, 197, 239, 281, 323 tools)
- | Scale feed back
- ★ | ★ | Automatic workpiece measuring device (with center of rotation axis measurement and measuring block)
- ★ | ★ | Setup
- | Non-contact tool length measuring device
- | 300 mm diameter circular table (T-slot, 200 kg weight load)
- | 500 mm diameter circular table (T-slot, 500 kg weight load)
- | 630 mm diameter circular table (T-slot, 350 kg / 500 kg weight load)
- | Pallet table specification (200 mm diameter / 300 mm diameter)
- | 400 × 400 Pallet table specification (tapped hole / T-slot, 300 kg weight load, 1pc pallet)
- | 500 × 500 Pallet table specification (tapped hole, 250 kg / 500 kg weight load, 1pc pallet) (T-slot, 500 kg weight load, 1pc pallet)
- | Pallet changer
- | Vertical 3-tire pallet magazine (12 pallets magazine)
- | Through spindle coolant (1.5 MPa / 7 MPa) and Air
- ★ | Shower coolant system (D300: 9 nozzles *6 nozzles when pallet changer is selected, D500: 15 nozzles)
- ★ | ★ | Tilttable chip bucket
- ★ | ★ | Tilt truck chip bucket
- | Conveyors in splash guard (hinge type)
- ★ | Lift-up chip conveyor with coolant filtration (Right discharge, scraper type / tank capacity 350 L / 600 L)
- | Lift-up chip conveyor with coolant filtration (Rear / Front discharge, scraper type / tank capacity 820 L) H1250
- ★ | ★ | MQL unit
- ★ | ★ | Coolant temperature controller (with heater)
- ★ | ★ | Thermal guard
- ★ | ★ | 3-dimensional circular interpolation
- ★ | ★ | 3-dimensional coordinate conversion
- | Customer specified machine color

D series

