

TruLaser Tube

Tubes prefer
TRUMPF

Accelerate growth with laser tube cutting

The world we live in is growing. And with it the demand for products on a large scale and in a wide range of materials. Tubes are an elementary part of this. With high growth rates, the market for laser-cut tubes offers exceptionally good chances of success. Choose laser tube cutting to stay on the cutting edge in the future.

The possibilities of technology

We are living in a world of tubes
4–5

Advantages compared with conventional tube cutting

Why process tubes with lasers?
6–7

Flexible and cost-efficient manufacturing

**Redesign and save on costs
8–11**

The right software

**Your product range
for the world of tubes
12–13**

Integrated components for best results

**Functions that take
you forward
14–15**

The TruLaser Tube family

**The right machine for you
16–23**

Your suitable total package

**Everything from a single
source
24–27**

We are living in a world of tubes

What does an intricate designer lamp share with the sturdy frame of a combine harvester or the complex tubular system of a scaffold? They are all produced from laser-cut tube and profile designs. No wonder, because no tool is as versatile and offers as much contouring freedom as a laser. You can find evidence of it in furniture, cars, commercial vehicles, transport, on construction sites, in mechanical engineering and plant construction, in agriculture, in the fitness industry, climate and energy technology, or in shopfitting.



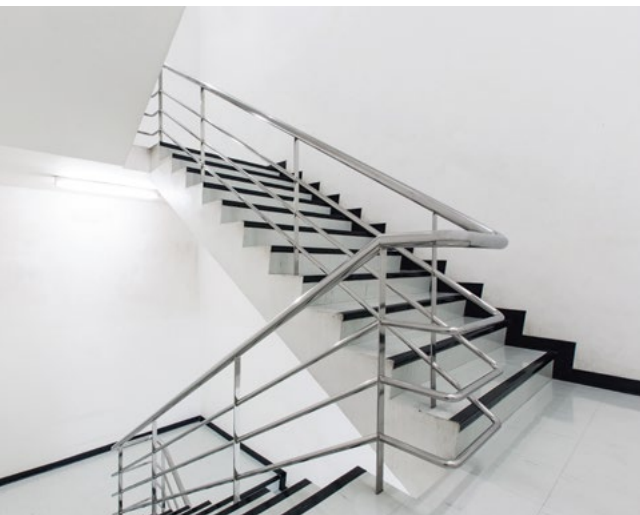

Why process tubes with lasers?

No need for sawing, drilling or deburring: Compared with conventional tube cutting the laser replaces a number of work steps. It can cut very precisely complex contours in materials such as mild steel, stainless steel, aluminum or nonferrous metal. Laser tube cutting offers a wide range of design options, opening the door to new products, customers, and orders.



"Laser tube cutting offers new design options for tube manufacturers to delight their customers. Innovative designs also offer a great potential for savings."

Norbert Beier, Head of Sales Laser Tube Cutting



Make full use of versatile contouring options

You can cut every conceivable contour with a laser beam. At the same time, machines are easy to use – your design options are almost unlimited.

Cost-effective manufacturing

Carry out several different work steps on a single machine, manufacturing parts precisely and quickly.

Save on tools

With the laser tool you can process different types of materials, wall thicknesses, and profile geometries in a completely noncontact procedure. Save time and money as there is no need to change tools.

Comparison of work steps for laser tube cutting and conventional production

Conventional production

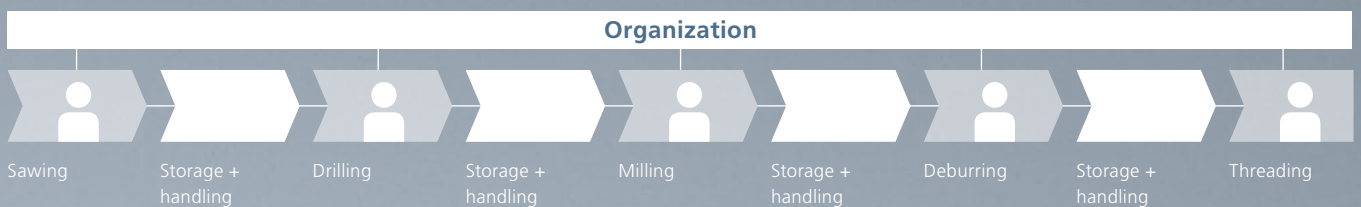

Laser tube cutting



Redesign and save on costs

Innovative tube designs save time and give you the technical edge: With bending frames, for example, you will need fewer parts. Positioning aids facilitate error-free assembly. The amount of work required for downstream work steps, for example welding, is noticeably reduced. And all this with just one machine.

How can you optimize your parts? Speak with our expert consultants on parts design to receive a wide range of tips that are tailored to your exact needs. Ready for optimal parts design?

Easier positioning, connecting and assembling

Clever designs with laser tube cutting simplify your processes: prepare your parts perfectly for subsequent work steps.

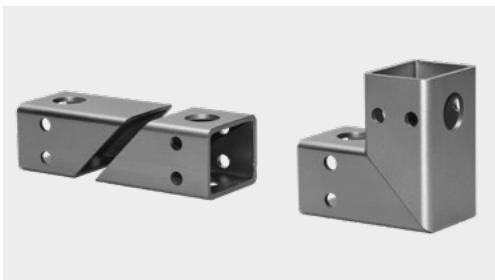

Thanks to bevel cuts of up to 45°, you can further process corner connections more quickly – with optimal material utilization.



Use tube-blank connections for simple fixing, optionally with lugs or coding function.

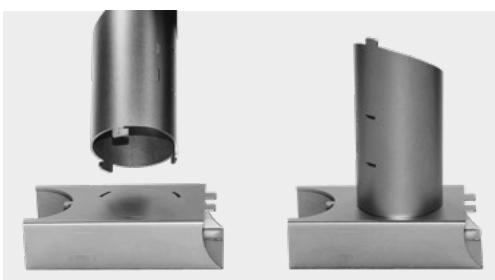

Replace time-consuming welding fixtures with plug, dovetail and bayonet connections.

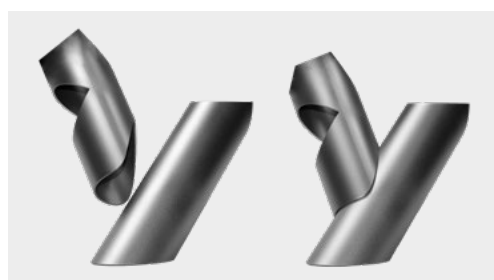

Connect tubes together easily using attachments – the perfect option for load-carrying tube designs.



Conventionally welded from two single parts.



Efficient production of bend connections and positioning aids with a laser.

Increased technical advantages, reduced parts costs

Get straight to the bottom line: thanks to bend connections, recesses and pins, you can reduce the time needed to make this sample part by 49% and the cost by 31%.

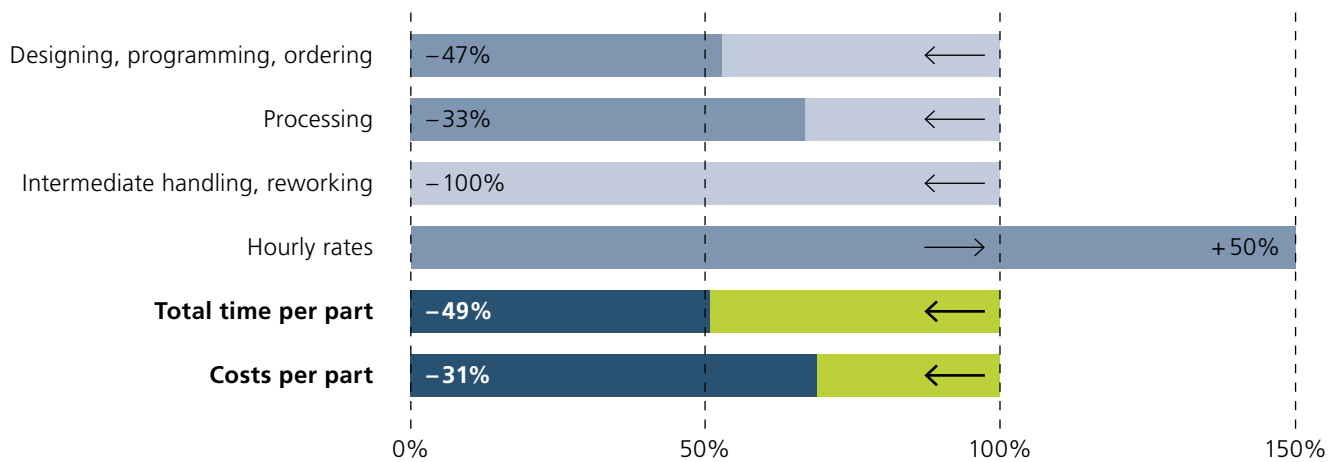

Laser tube cutting with TruLaser Tube

Conventional production (sawing, milling, drilling)

Better utilization for greater profit

Would you like to increase your vertical range of manufacture, improve your machine utilization rate, or lower the costs for fixtures? Then you should manufacture fixtures from laser-cut tubes in the future. It's easier than you think.

Tube fixture design

Simply produce your own fixtures

The design of tube fixtures allows you to tap into an additional application field, and utilize more of your laser tube cutting machine's capacity. Learn about the design rules for tube fixtures and how you can optimally design your assemblies through training sessions and consultations. These will allow you to design, adapt, and replicate assemblies quickly and cost-effectively in the future.

The example shows that while the conventionally manufactured welding fixture needs to be laboriously adjusted via a clamping device, the new design features a spring effect for tolerance compensation.

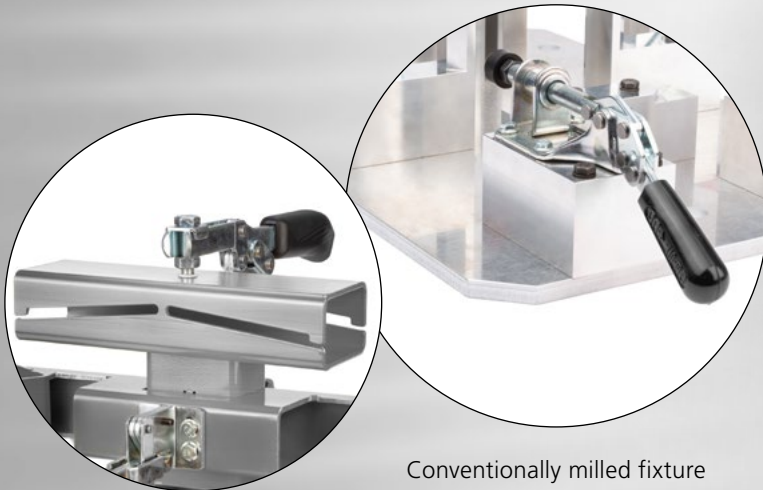

Conventionally milled fixture

Optimized fixture made from tubes

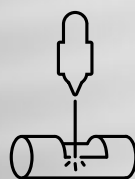

Laser tube cutting
parts, including all inner geometries and joining aids in pin form

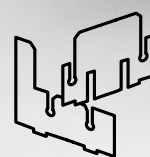

Assembling
and welding the two single parts



Cleverly designed welding fixture

Ergonomic solution including spring effect and tolerance compensation

A tube plug-in design replaces the entire milling block. The laser tube cutting machine not only cuts the tube cross section to size, it also provides all parts with joining aids, which allow for precise positioning. The laser tube cutting machine also creates threads directly.



You benefit from fewer parts and less effort. Only one clamping device is required in the upper clamping tube. The visible longitudinal sections provide a spring effect to the fixture and compensate for the tolerances in the component. The vertical design of the fixture makes it easily accessible and ergonomic. The entire welding assembly can now be welded in one clamping, in the exact size, and with higher quality. All in all, the manufacturing time and weight are reduced.

-80%
in costs

Your product range for the world of tubes

The 3D software Programming Tube takes you quickly, easily and intuitively to the NC program. Thanks to strong automatism, no programming is required for many finished parts. Numerous cases, for example automatic production of innovative bend connections and positioning aids, are already stored. The software solution also offers flexible data import and powerful design, supporting you throughout the entire programming process.

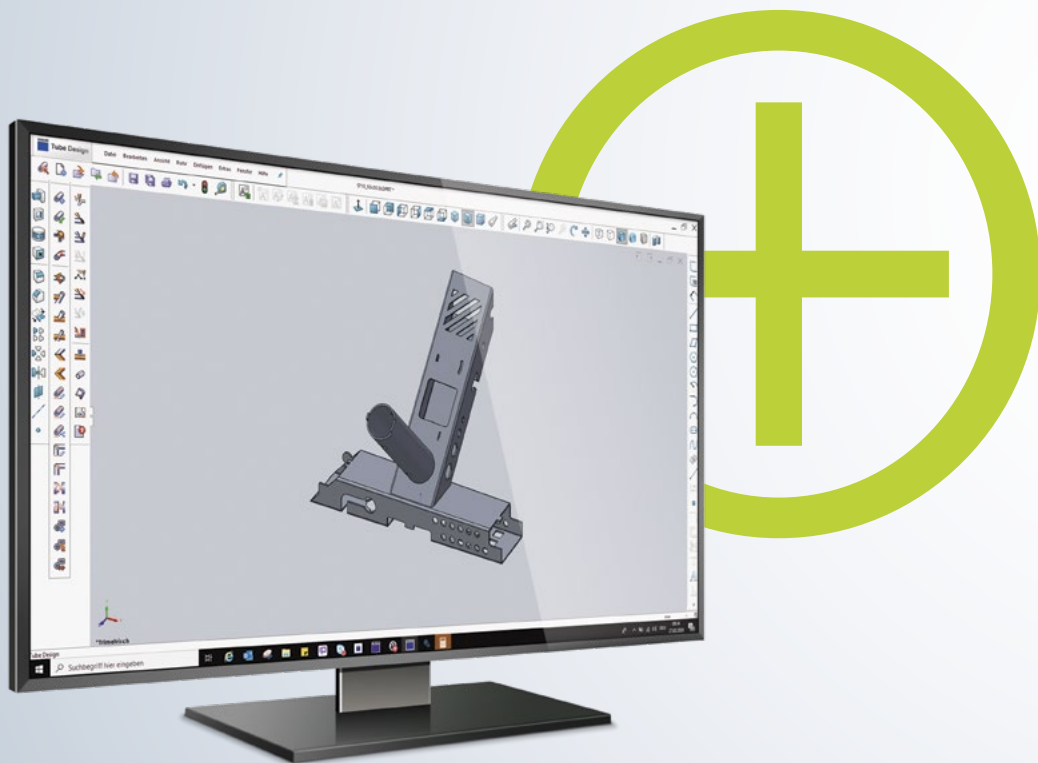

Programming Tube

- Programming system for tube and profile processing
- Strong automatism: Parts already programmed when loading
- Easy to learn thanks to modern, intuitive user interface
- Direct manipulation: Change processing directly in 3D
- Optimize parameters in the running simulation
- Preset rules and TRUMPF cutting data

Automatic programming of threads

Based on the thread parameters, Programming Tube automatically creates the NC program including tools and processing sequence.

Flexible data imports

Import all common formats in Programming Tube. The program corrects incorrect data as well as rounding radii and splits up their assemblies.

Adding tube connections

Design positioning aids and bend connections with just a few clicks of the mouse and reduce your rejects. Positioning aids simplify downstream work steps such as mounting or welding. Bend connections help you to connect tubes more precisely and quickly.

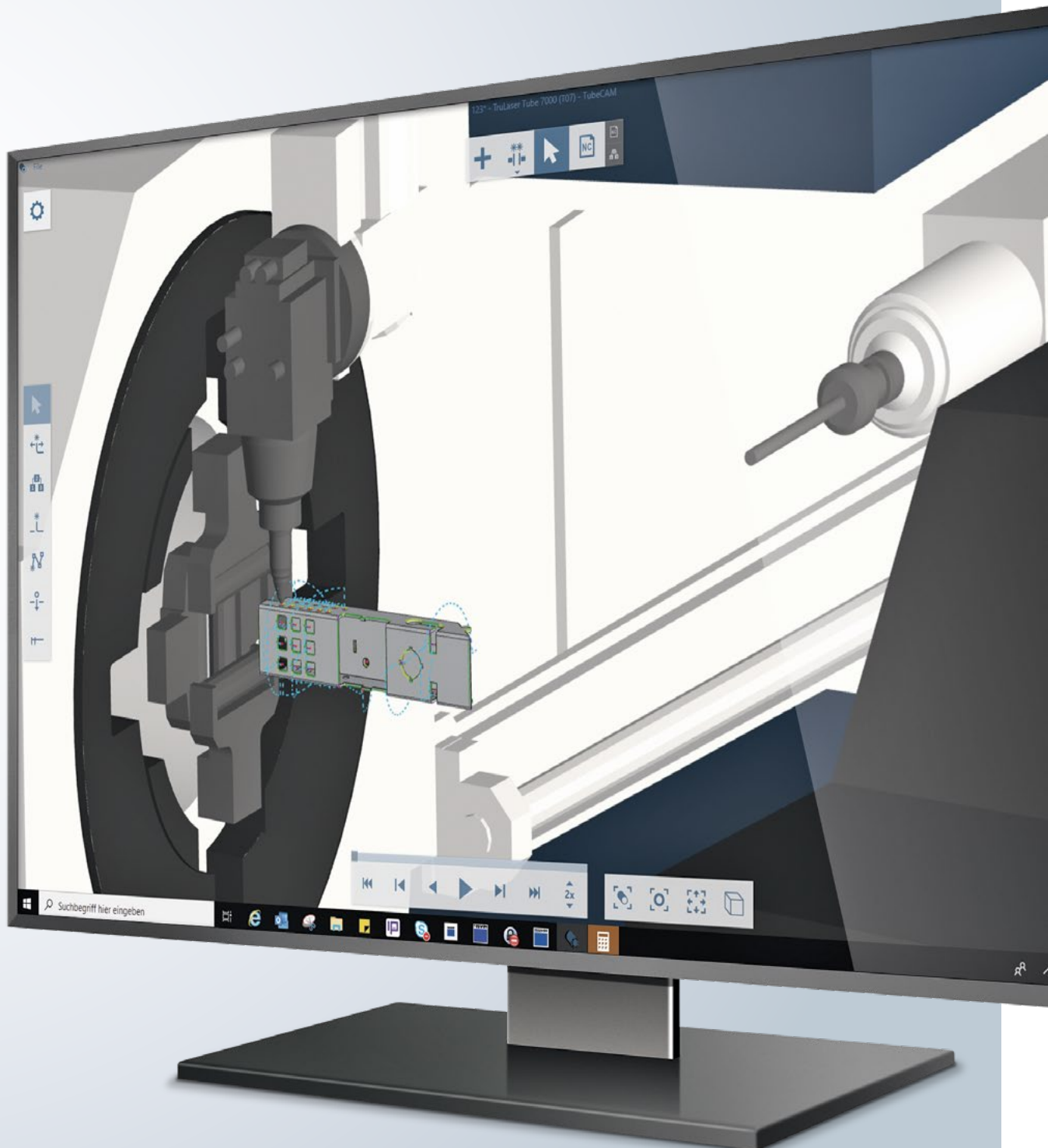

Functions that take you forward

With clever functions and integrated expertise, your TruLaser Tube simplifies the path of your tubes and profiles through the machine. From loading to cutting and unloading to downstream processes, the purpose is clear: to help you build on your competitive edge.



- **Safe and automatic loading** even of special profiles – Smart Profile Detection detects the position and orientation of the profile with the help of sensors and adapts the cutting program accordingly.
- **Automatic tube alignment** is carried out by SeamLine Tube. It detects weld seams or markings and aligns the tube suitable to the cut geometry.
- **Quick and efficient manufacturing of small lot sizes is** facilitated by the pivoted manual conveyor system. Loading is automatic and also perfectly suited to special profiles.



- **Productive manufacturing of material thickness up to 3 mm** using the function RapidCut. It uses the high feed rates of the solid-state laser even with small contours, allowing you to process your parts up to 30% faster.
- **Reduce piercing times** with PierceLine, depending on the material type and thickness, by 10–60% compared to preset values.
- **One cutting head for all wall thicknesses** is all you need thanks to the single cutting head strategy of TRUMPF.
- **Protect the cutting head and avoid collisions** using the Controlline function – the distance between the cutting nozzle and the surface remains constant, even with uneven tube surfaces. The magnetic coupling minimizes the impact of unavoidable collisions.
- **Reduce rejects and material costs** with the help of AdjustLine. It helps you cut even lower quality material quickly and easily.
- **Adapt the focus position to the material type and thickness** using the automatic FocusLine function.



Unloading

- **Sort parts according to orders** with the help of wire mesh boxes, customer-specific containers, or conveyor tables which protect your materials.
- **Automate loading and unloading even further** using the digital unloading interface, for example by connecting a robot.



Simplify downstream processes

- **Prepare bevel edges optimally** using the bevel cut function with patented TRUMPF technology for high-quality bevel cuts up to 45°.
- **Apply threads in a single work step** using the technology package for tapping directly on your machine. Using an NC-controlled spindle unit, you can carry out processes such as twist drilling, thread cutting, flow drilling, and tapping.
- **Clean inside of tubes** are ensured by the spatter protection device for round tubes, avoiding the need for reworking.
- **Identify your parts** easily using a Dot Matrix Code.

TruLaser Tube 3000 fiber

The machine that's always worth it for laser tube cutting.



01

Cost-effective

even when it is not fully utilized

02

Reliable

thanks to robust design and intelligent functions

01

Cost-effective

even when it is not fully utilized

Whether you want to insource quality, require flexible manufacturing to tight deadlines, or want to win new customers and markets: this machine pays for itself, even if you don't utilize it fully.

02

Reliable

thanks to robust design and intelligent functions

No need for time-consuming manual setting of the machine that is more likely to cause errors, as the machine automatically performs many of the tasks itself. It uses ControlLine to avoid collisions and AdjustLine to cut lower quality material safely. Thanks to FocusLine, the focus is always in the right place.

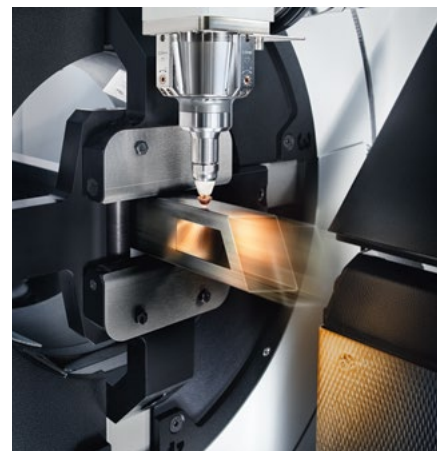

^[1] Manual loading of round tubes with outside diameter of 152 to 170 mm optionally possible. ^[2] Value for larger versions (option). Content subject to change without notice. Only specifications in our offer and order confirmation are binding.

Max. outside diameter of round tube in mm: 152^[1]
 Max. outer circle diameter of rectangular tube in mm: 170
 Max. workpiece weight in kg/m: 18.5 (120/148 kg total)^[2]



03

Easy
to handle

04

Precision
cutting and clamping

03

Easy
to handle

Easy to operate: minimal setup times, outstanding accessibility – so that you never lose sight of the process. Loading and unloading can easily be carried out manually or automatically using LoadMaster Tube, crane, or part removal flap.

04

Precision
cutting and clamping

Its precision matches that of the 5000 and 7000 series: high-precision clamping system, exact optics setup and precise tube guidance for best part quality. Thanks to the adaptive clamping system, you can process L- and U-profiles yourself.

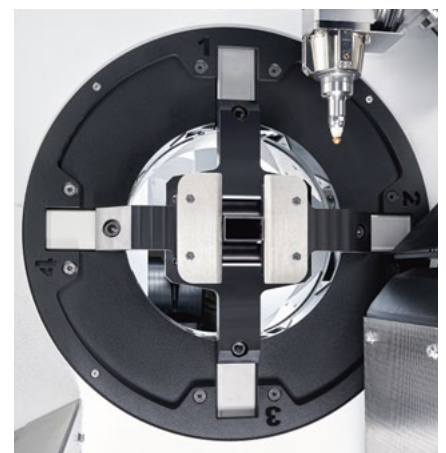

More information about the TruLaser Tube 3000 fiber can be found here:
https://www.trumpf.com/en_INT/products/machines-systems/laser-tube-cutting-machines/trulaser-tube-3000-fiber/



TruLaser Tube 5000 fiber

Solid-state laser technology for fast and flexible processing. The TruLaser Tube 5000 fiber uses these strengths more than any other laser tube cutting machine has ever done before.



01

Highly productive

with solid-state laser and RapidCut

02

Setup-free

thanks to clamping system

01

Highly productive

with solid-state laser and RapidCut

Thanks to RapidCut, the high feed rates of the solid-state laser come into their own even with smaller contours. With thin material in particular, this is a huge productivity advantage.



With RapidCut, you can reduce part cutting times for material thicknesses of up to 3 mm.

02

Setup-free

thanks to clamping system

Setup is so outmoded – the clamping system of the TruLaser Tube 5000 fiber lets you produce tubes in the entire standard clamping range with no setup. The step rollers automatically adjust to the different diameters of the pipes.

Max. outside diameter of round tube in mm: 152^[1]
 Max. outer circle diameter of rectangular tube in mm: 170^[2]
 Max. workpiece weight in kg/m: 25 (162.5/200 kg total)^[3]

04

Easily expandable

for follow-up processes such as tapping

03

Perfectly accessible

thanks to intelligent beam guard

03

Perfectly accessible

thanks to intelligent beam guard

Tube processing by solid-state laser is not only possible with a complete housing – the open machine concept makes your TruLaser Tube 5000 fiber optimally accessible. Load and unload individual tubes quickly and easily from the front.



04

Easily expandable

for follow-up processes such as tapping

Easily integrate further processes: With the technology package for tapping, you can carry out machining processes such as flow drilling, tapping, and twist drilling. In the laser network, you can operate several TRUMPF machines with one laser.



More information about the TruLaser Tube 5000 fiber can be found here:
https://www.trumpf.com/en_INT/products/machines-systems/laser-tube-cutting-machines/trulaser-tube-5000-fiber/



TruLaser Tube 7000 fiber

Highest level of productivity –
even for XXL tubes.



01

Dynamic and productive

with solid-state laser and RapidCut

02

XXL

tubes up to 254 mm diameter

01

Dynamic and productive

with solid-state laser and RapidCut

The superimposed movement of the tube axis and cutting head increases the dynamics of your machine by more than four times. Thanks to RapidCut, the high feed rates of your solid-state laser come into their own even with smaller contours. With thin material in particular, this is a huge productivity advantage.



With RapidCut, you can increase the acceleration by up to four times.

02

XXL

tubes up to 254 mm diameter

With your TruLaser Tube 7000 fiber, you can cut through a wide range of tubes and profiles with lengths of up to 12.5 m. This also includes extra-large tubes and profiles with outer circle diameters of up to 254 mm and wall thicknesses of up to 14 mm for mild steel.

Max. outside diameter of round tube in mm: 254
 Max. outer circle diameter of rectangular tube in mm: 254
 Max. workpiece weight in kg/m: 40

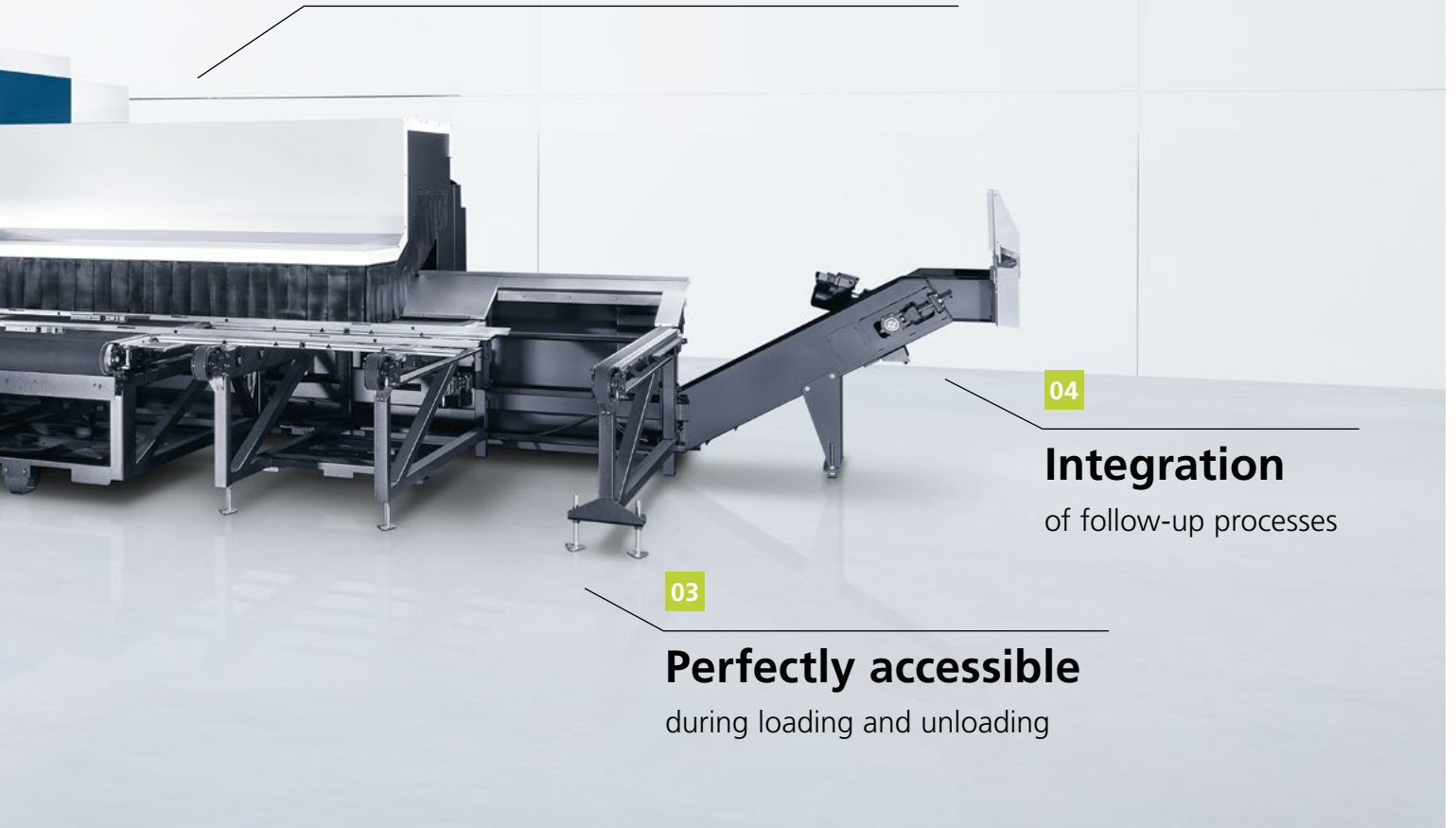

04

Integration
 of follow-up processes

03

Perfectly accessible
 during loading and unloading

03

Perfectly accessible
 during loading and unloading

The open machine concept makes your TruLaser Tube 7000 fiber optimally accessible. This allows you to load individual XXL tubes – for example by crane – quickly and efficiently. For small lot sizes and special profiles you can use the swivel-mounted conveyor system.



04

Integration
 of follow-up processes

Carry out follow-up processes on your machine with ease: With the optional technology package for tapping, for example, you can carry out machining processes such as flow drilling, tapping, and twist drilling – automatically.



More information about the TruLaser Tube 7000 fiber can be found here:
https://www.trumpf.com/en_INT/products/machines-systems/laser-tube-cutting-machines/trulaser-tube-7000-fiber/



Technical data

Here is the technical data for our TruLaser Tube machines and an overview of the availability of intelligent functions.

Laser data		TruLaser Tube 3000 fiber		TruLaser Tube 5000 fiber		TruLaser Tube 7000 fiber		
		TruFiber 2001	TruFiber 3001	TruDisk 3001	TruDisk 4001	TruDisk 3001	TruDisk 4001	TruDisk 6001
Max. power	kW	2	3	3	4	3	4	6
Average power input in production	kW	6	9	9	10	9	10	12
Max. material thicknesses								
Mild steel	mm	8	8	8	10	8	10	14
Stainless steel	mm	4	6	5	6	5	6	10
Aluminum	mm	4	6	6	6	6	6	10
Copper/brass	mm	3	4	4	5	4	5	5

Content subject to change without notice. Only specifications in our offer and order confirmation are binding.

Available functions/options	TruLaser Tube 3000 fiber	TruLaser Tube 5000 fiber	TruLaser Tube 7000 fiber
AdjustLine	■	■	■
Digital loading and unloading interface	■	■	■
Dot Matrix Code	■	■	■
Conveyor system	■ (nonswiveling)	■ (nonswiveling)	■ (swiveling)
Magnetic coupling/Controlline/FocusLine	■	■	■
PierceLine	■	■	■
RapidCut	■	■	■
Bevel cut	■	■	■
SeamLine Tube	■	■	■
Smart Profile Detection		■	■
Sorting function unloading point			■
Spatter protection device			■
Technology package for tapping		■	■

TruLaser Tube 3000 fiber		
Max. outside diameter of round tube	mm	152 ^[1]
Max. outer circle diameter of rectangular tube	mm	170
Max. unprocessed material length for automatic loading	mm	6500 8000 ^[3]
Max. finished part length	mm	3000 4750 ^[3] 6500 ^[3]
Max. workpiece weight	kg/m	18.5 (120 148 ^[3] kg total)
Available lasers		TruFiber 2001 TruFiber 3001

Content subject to change without notice. Only specifications in our offer and order confirmation are binding.

TruLaser Tube 5000 fiber		
Max. outside diameter of round tube	mm	152 ^[1]
Max. outer circle diameter of rectangular tube	mm	170 ^[2]
Max. unprocessed material length for automatic loading	mm	6500 8000 ^[3]
Max. finished part length	mm	3000 4500 ^[3] 6500 ^[3] 8000 ^[3]
Max. workpiece weight	kg/m	25 (162.5 200 ^[3] kg total)
Available lasers		TruDisk 3001 TruDisk 4001

Content subject to change without notice. Only specifications in our offer and order confirmation are binding.

TruLaser Tube 7000 fiber		
Max. outside diameter of round tube	mm	254
Max. outer circle diameter of rectangular tube	mm	254
Max. unprocessed material length for automatic loading	mm	6500 9200 ^[3] 12500 ^{[3][4]}
Max. finished part length	mm	4500 6000 ^[3] 6500 ^[3] 8000 ^[3]
Max. workpiece weight	kg/m	40 ^[4] (260 368 ^{[3][4]} kg total)
Available lasers		TruDisk 4001 TruDisk 6001

Content subject to change without notice. Only specifications in our offer and order confirmation are binding.

^[1] Manual loading of round tubes with outside diameter of 152 to 170 mm optionally possible. ^[2] Max. outer circle diameter of rectangular tube 180 mm optionally possible. Rectangular profiles with side length > 152.4 mm only with manual loading. ^[3] Value for the enlarged design (option).

^[4] When using automated loading with LoadMaster Tube 12.5 m, the total maximum weight is 368 kg or 30 kg/m. When loading manually, the total maximum weight is 500 kg or 40 kg/m.

TruServices. Your Partner in Performance

For a successful future, choose services that will help you progress in the long term: Whether you want to create the best conditions for successful manufacturing, make the most of your TRUMPF laser systems, or have the flexibility to adapt them to changing requirements – together we will find opportunities to maximize your value creation long-term. We will provide you with all-round support as a reliable partner with solutions and service packages for your needs – enabling you to manufacture economically and at a constantly high level.

EMPOWER

If you want to create the best conditions for successful production, we will support you in this.



Training – reach your full potential with professional development

If you are well trained, you can fully utilize the potential of your lasers, laser systems, machines and software, and secure key competitive advantages. Take advantage of the opportunity to improve your knowledge now and always react flexibly to new requests from your customers.

SUPPORT

If flexibility and availability of equipment in day-to-day operations are essential to you, we can help.

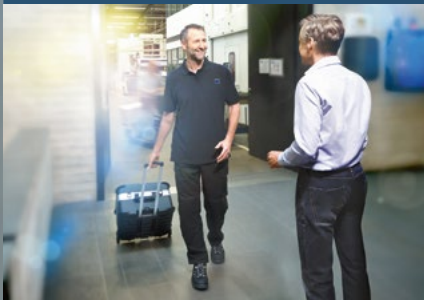

Service app – the app for your service messages

Whether it's a technical problem, software, a spare part or a question concerning maintenance: with the Service app and your free MyTRUMPF account, you can send your service messages quickly and easily to our Technical Service team at any time.

IMPROVE

If you want to gradually focus your production on maximum value creation, we can help you achieve your goal.



Service agreements – get just the service you need

Where system maintenance and servicing are concerned, you will benefit from expert support of the highest quality. Ensure constant maximum machine availability, consistently high production quality, and low operating costs with service agreements from TRUMPF.



 Financing	 Training	 Technical Service	 Genuine parts	 Tools	 Service agreements
 Software	 Process optimization	 Monitoring & analysis	 Product enhancements	 Pre-owned machines	



You can learn more about our complete and comprehensive package of useful services here: www.trumpf.com/s/services



Passion is what drives us

Whether it's production and manufacturing technology, laser technology, or material processing – we develop highly innovative products and services for you which are tailored to your industry and which are absolutely proven and reliable. We put everything we've got into giving you a compelling, competitive edge: expertise, experience, and above all passion.



Check out our
YouTube channel:
[www.youtube.com/
@TRUMPFtube](http://www.youtube.com/@TRUMPFtube)

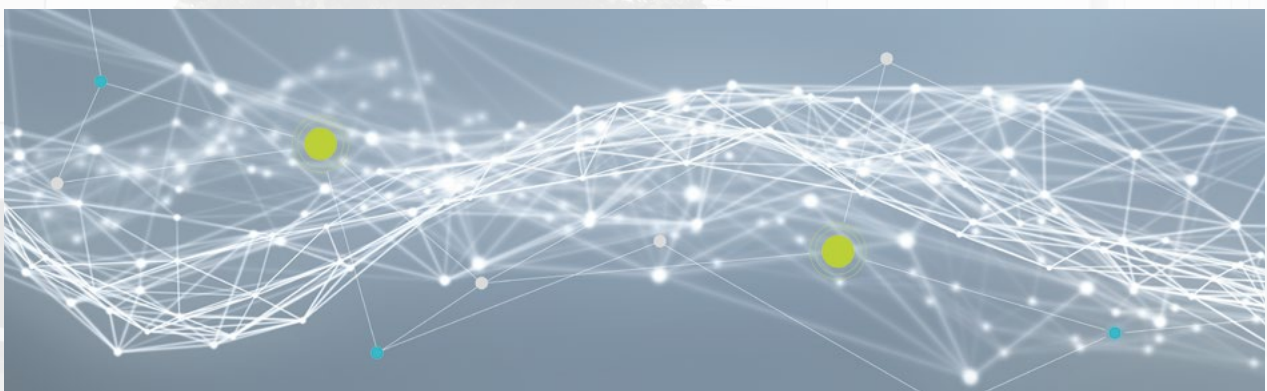

Solutions for your future

With a step-by-step introduction to your Smart Factory, you can take advantage of digital networking opportunities. We partner with you on the path to networked production, delivering pragmatic, economical solutions that make your processes both more transparent and flexible.

This will allow you to maximize your resources while ensuring your production is fit for the future. We support you every step of the way until your production runs perfectly for your needs.

Machines & systems

Laser cutting in 2D and 3D, punching, bending, laser welding and punch laser processing: With custom-fit machine tools, laser systems, software, and automation from TRUMPF, you can master flexible sheet metal and tube processing. Additive manufacturing solutions round off our portfolio – a portfolio that includes consulting, software, and services.



Lasers

Whether for cutting, welding, marking or processing surfaces, with lasers from TRUMPF you have the universal tool for your industrial applications. Choose the ideal system solution for you from the macro, micro and nano ranges. We will also support you with software solutions, application knowledge and consulting.



VCSEL solutions & photodiodes

Laser and photodiodes from TRUMPF Photonic Components come into their own in numerous applications: in the industrial and consumer markets and even in optical data communication. A VCSEL (Vertical Cavity Surface Emitting Laser) laser diode emits light perpendicular to the plane of the semiconductor chip. In the TruHeat VCSEL systems, millions of VCSELs generate infrared heat, which is used for laser heat treatment.

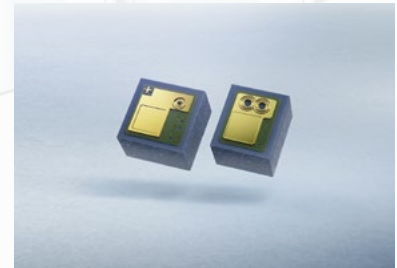

Power electronics

Nothing's hi-tech without a process power supply: With generators for plasma technology, industrial heating, battery inverter systems and microwave amplifiers, you get power at the frequency and performance you need. These technologies can be found in smartphones, for example, on glass facades, in PV systems or in microchips.



Power tools

Whether for cutting, connecting, and edge forming of sheet metal, professionals all over the world rely on the user-friendly electric and battery-powered tools from TRUMPF. On construction sites and in workshops, the quality products manufactured in Switzerland convince, gain and retain fans with their modern technology and perfect handling.



TRUMPF is certified to ISO 9001
(Find out more: www.trumpf.com/s/quality)

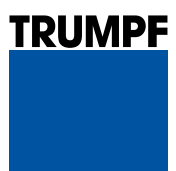

TRUMPF Werkzeugmaschinen SE + Co. KG
www.trumpf.com